

**भारत प्रतिभूति मुद्रणालय INDIA SECURITY PRESS**

नाशिक रोड - 422101 (महाराष्ट्र) / NASHIK ROAD - 422101 (MAHARASHTRA)

(भारत प्रतिभूति मुद्रण तथा मुद्रा निर्माण निगम लिमिटेड की इकाई / A UNIT OF SECURITY PRINTING & MINTING CORPORATION OF INDIA LTD.)

भारत सरकार के पूर्ण स्वामित्वाधीन / WHOLLY OWNED BY GOVERNMENT OF INDIA

(आई एस ओ - 9001 : 2015 एवं 14001 : 2015 प्रमाणित कंपनी / ISO - 9001 : 2015 & 14001 : 2015 Certified Company)

मिनिरत्न श्रेणी-I, सीपीएसई / Miniratna Category - I, CPSE

फोन / PHONE : +91-253-2402200

फैक्स / FAX : +91-253-2462718

CIN : U22213DL2006GOI144763

वेबसाइट / website : https://ispnasik.spmcil.com

ई-मेल / e-mail : isp@spmcil.com; purchase.isp@spmcil.com

Ref No.: SY-15-13-VDP-1/2024

Date: 03.10.2024

**CORRIGENDUM-1**

REFERENCE: ISP GeM Bid No. GEM / 2024 / B / 5362010 dated 05.09.2024 floated by ISP-Nasik for 'Procurement of UV Variable Printing & Slitting Machine' (Qty.: One No.).

In context with the above referred ISP GeM Bid, the following amendments are hereby authorized to be read as:

Sr. No.	ISP Clause no.	ISP Clause Description	Read as
<b>A) General features of substrates to be used:</b>			
1	A.3	Core ID of reel (in mm) - 76±2	Core ID of reel (in mm) = 76 MM
2	A.6	Substrate grammage (in GSM) - 50 to 250	Substrate grammage (in GSM) = 50 to 180
3	A.7	Substrate thickness (in microns) - 50 to 300	Substrate thickness (in microns) = 50 to 200
4	A.8	Nature of substrate - uncoated paper/paper board/composite, clay coated paper/paperboard/composite, glassine paper, silicon coated paper, PET, polyester, OPP, BOPP, LDPE, HDPE, Polyolefin etc.	Nature of substrate - uncoated paper/composite, clay coated paper/composite, glassine paper, PET, polyester.
<b>B) Unwinding, Web handling, Web transport, Slitting unit and Turret rewinding unit</b>			
<b>I. Unwinding Unit: Fig. 1, 2 &amp; 3 for working mechanism are attached at Annexure-1.</b>			
<b>III. Slitting unit</b>			
5	B.III.3	Minimum slitting width to be supported= 35 mm or less.	Minimum slitting width to be supported= 35 mm or lesser will be preferable.
<b>IV. Turret Rewinder unit with Automatic splicing:</b>			
6	B.IV.6	The change over from running web to standby web to be executed at machine speed from 180 meters/min or higher.	The change over from running web to standby web to be executed at machine speed from 150 meters/min or higher.
7	B.IV.9	Double sided adhesive tape applicator for core end of 'empty spools'.	Double sided adhesive tape applicator for core or gluing arrangement with suitable dispenser.
<b>V. General conditions</b>			
8	B.V.1	All the unwinding & rewinding shafts/mandrels shall be air expandable with multi tubes inside it. There shall be provision for inflating/deflating the air expandable shafts through option available on HMI.	All the unwinding & rewinding shafts/mandrels shall be air expandable with multi tubes inside it. There shall be provision for inflating/deflating the rewinding air expandable shafts through option available on HMI. There shall be suitable arrangement for inflating or deflating the unwind shaft using air pressure gun or other better arrangement.
9	B.V.5	High resolution touch screen HMI of display size 15" or more consisting features for speed control, tension control, programmable spool formation, programmable rotary knives positioning, core positioning, pressured air status within air expandable shafts and other features to be provided. Minimal use of physical buttons will be preferable.	High resolution touch screen HMI of display size 12" or more consisting features for speed control, tension control, programmable spool formation, programmable rotary knives positioning, core positioning, pressured air status within air expandable shafts and other features to be provided. Minimal use of physical buttons will be preferable.

Sr. No.	ISP Clause no.	ISP Clause Description	Read as
<b>D) Drop on Demand Inkjet printing system</b>			
<b>I. Printing Hardware</b>			
10	D.I.11	There should be provision for stitching the print heads within the print module so as to produce 'No Gap' printing across the defined print width of 510 mm or higher. The alignment and movement of print heads within the print module as well as the print module shall be automatically controlled by means of motors actuated through commands from operator HMI/controller	the print heads within the print module shall be stitched so as to produce 'No Gap' printing across the defined print width of 510 mm or higher.
<b>IV. RIP/Workflow Software/Printing Software</b>			
11	D.IV.7	Shall be compatible with all standard file formats like (.pdf),(.csv),(.xls), (.txt), Unicode etc	Shall be compatible with all standard file formats like (.pdf),(.csv),(.txt), Unicode etc
12	D.IV.9	There shall be no limitation on the number of fields that can be linked to any object/message from database. It should also be able to link fields from multiple external databases in a single message for printing text/2D code/Quadra code.	There shall be no limitation on the number of fields that can be linked to any object/message from database. The system shall have the ability to link multiple field from multiple databases in layout or it shall have the ability to link multiple field from a consolidated single database that has been formed by merging multiple database through the in built software.
<b>G) Logical Integration of machine</b>			
<b>II. Interaction between VDP Inspection system and Turret Rewinder</b>			
13	G.II.2	The splicing shall take place in between the two consecutive rows labels printed with 'cancel'/any other custom message command.	The splicing shall take place in between the consecutive rows not more than 6 rows to be wasted for this implementation) printed with 'cancel'/any other custom message command.
<b>H) General Technical Specifications</b>			
14	H.II.C	Program of the PLC/HMI system along with complete access to be provided in the service laptop	Program of the PLC/HMI system along with complete access to be provided in the service laptop wherever applicable.
15	I.4	The firm has to provide back up of all PLC program, drive program parameters and source code of all customised software built for INDIA SECURITY PRESS, NASHIK along with a dedicated laptop for servicing.	The firm has to provide back up of all PLC program, drive program parameters and source code of all customised software built for INDIA SECURITY PRESS, NASHIK along with a dedicated laptop for servicing wherever applicable.
<b>L) Pre-Dispatch Inspection</b>			
16	L.5	During PDI, Required Trial material like dummy pre-printed sticker paper and pre-printed polymer-based label stock of minimum and maximum specified GSM/thickness as per Para-A, VDP Ink for PDI trial will be arranged by the Supplier & the necessary information for label size will be provided by ISPN to the successful vendor in advance.	During PDI, ISP will provide 4 unprinted stock reels for trial and testing purpose on returnable basis.
<b>Payment Terms:</b>			
17	25.	The 100% payment will be released after successful installation, testing commissioning & training and its acceptance and on submission of required documents.	i. 80% of the machine cost on successful completion of PDI and receipt of goods at ISP-Nasik and on production of all required documents by the supplier. ii. 20% of machine cost and 100% of the installation, commissioning and training (ICT) cost on successful installation, commissioning and acceptance by the user department.

**Note\*:** a. All other terms and conditions of PQB notice shall remain unchanged.

b. For further details, please visit our website [www.spmcil.com](http://www.spmcil.com) or <https://ispnasik.spmcil.com> regularly.

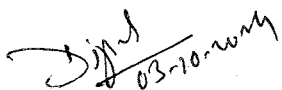
  
 Addl. General Manager (Materials)  
 For Chief General Manager

Figure-1:

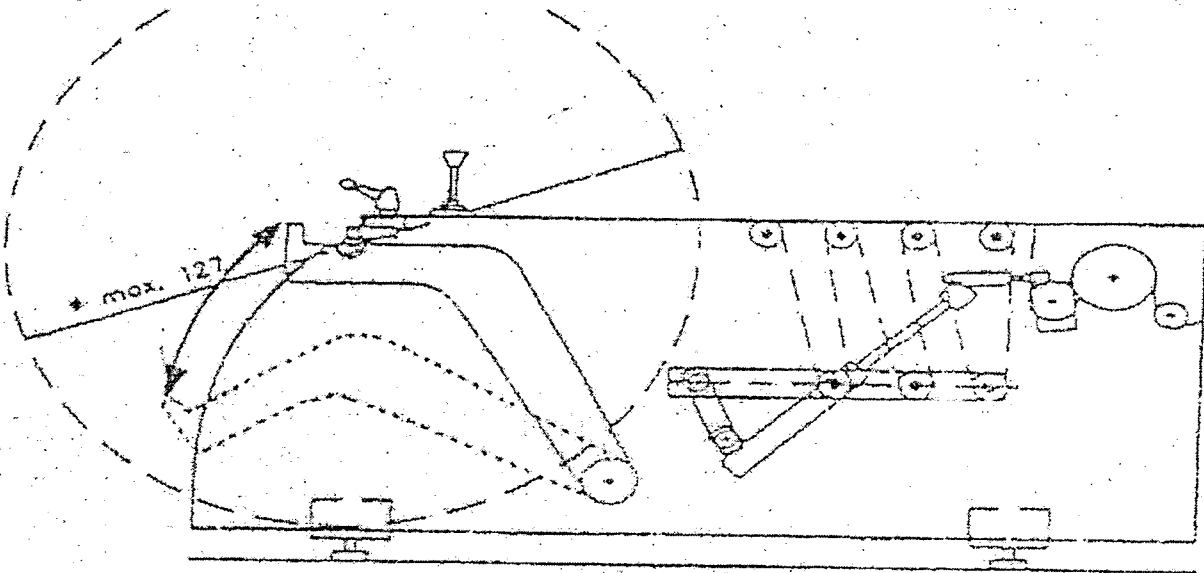


Fig. 6 Carrying the reel.

Figure-2:

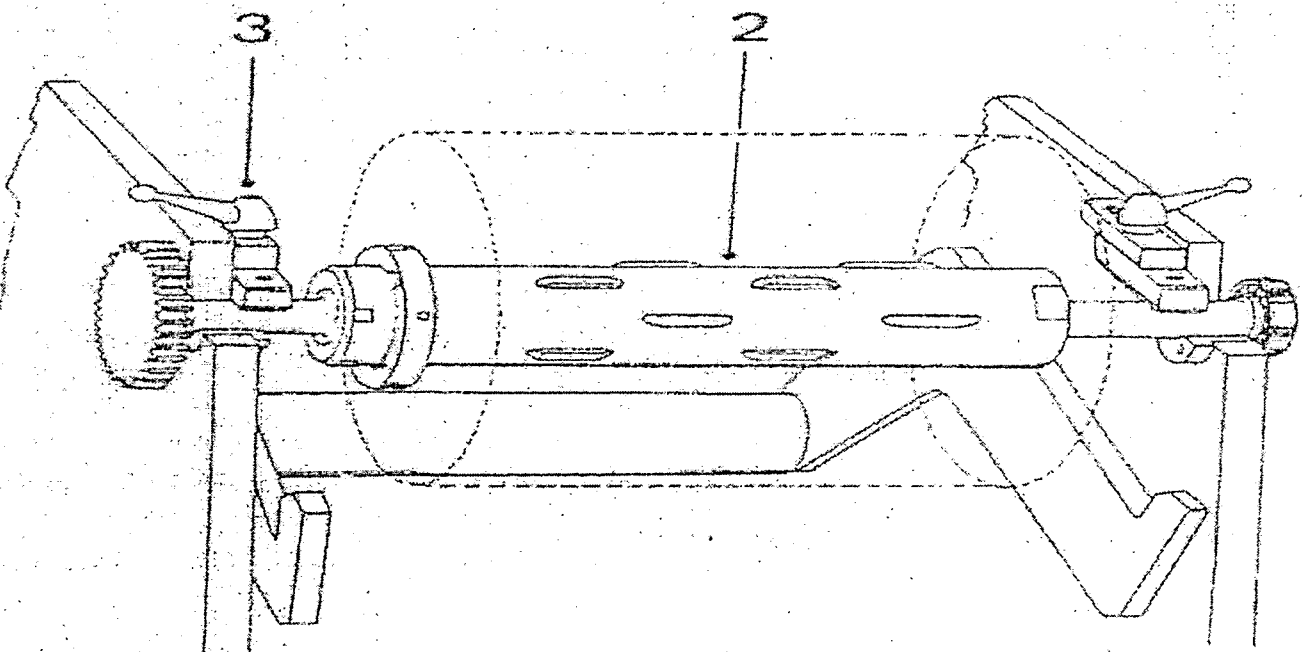


Figure-3:

